



## AC Current Sensor Switch

### Operating principle

Normally open: CSS-030

When the current of the perforation line exceeds the set value, the red light goes on and the output signal is a closed one; when the current is below the set value, the green light goes on and the switch is open.

### Product parameters

Monitoring current: 0.2-30A AC  
 Contact capacity: 0.3A@240V AC/DC  
 The diameter of the perforation line: 10MM  
 Dimensions: 65\*25\*47MM  
 Maximum leakage value: 0.1MA  
 Maximum overload capacity: 100%  
 Operating temperature: -20-55°C  
 Hysteresis: less than 1%  
 The shell color: black/blue

- >Mutual inductance current monitoring, security isolation of input and output, self power
- >The range of the monitored current is up to 30A; the monitoring threshold is adjustable within 0.2-30A.
- >Hysteresis is less than 1%. It can be used in strong magnetic environment.
- >Non-contact electronic switch with fast reaction and unlimited number of on-and-off operations.
- >The shell is made of environmentally-friendly flame-retardant PC material.

### Current action threshold setting

- 1.The current value of the perforation line is adjusted to the switch action threshold to be set.
2. Adjust the current regulator on the switch to the position where the red light and the green light just switch.

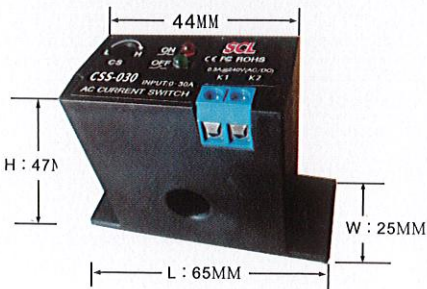

[www.switchtec.com](http://www.switchtec.com)

### Wiring schematic diagram

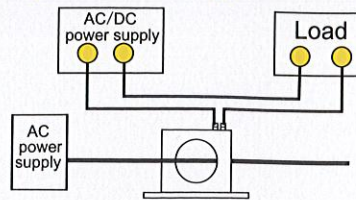

Note:

Monitoring AC current

- 1.The contact capacity of the switch: 0.3A@240V AC/DC.
- 2.Only one-phase electricity is monitored.

### Sample 1: The relay/contactor is used to control the AC and DC load indirectly.

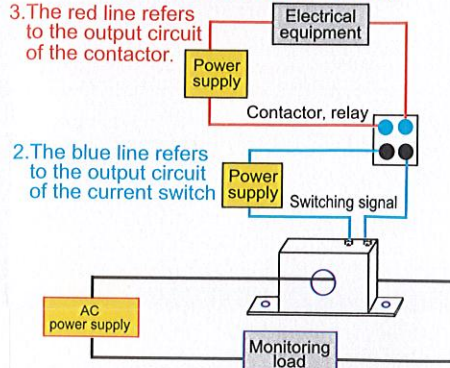

3.The red line refers to the output circuit of the contactor.

2.The blue line refers to the output circuit of the current switch

- 1.The black line refers to the input circuit of the current switch (the circuit of the equipment to be monitored)

### Sample 2: As a signal source, the current transformer switch is used together with PLC to achieve intelligent control or intelligent protection

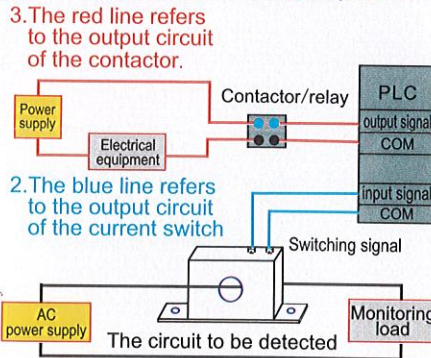

3.The red line refers to the output circuit of the contactor.

2.The blue line refers to the output circuit of the current switch

- 1.The black line refers to the input circuit of the current switch (the circuit of the equipment to be monitored)